

R.A.B

Retrofit Automatic Brush

"Turn any Custom Technology Co. B.I.G. or G.N.G. filter into an automatic self-cleaning system.

An Existing CTC Filter Unit



The RAB can be field retrofitted onto CTC units now in operation. No modification necessary to existing filters.

CTC Filter Unit with the R.A.B. installed



Available for remote filter sites with no power available. Standard unit requires 120V AC, 5 amps power source.



Custom Technology Co., Inc.

460 McLaughlin Road • Yakima, WA 98908
(509) 965-3333 • FAX # 965-9309

"INNOVATIVE ENGINEERING & MANUFACTURING"

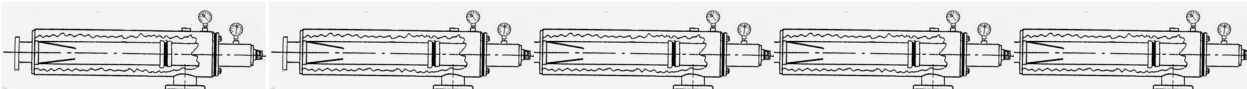

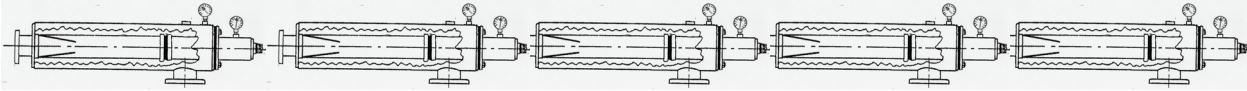

Introduction

Your new R.A.B. converts your CTC pressure filter into an automatic self-cleaning system. It will fit the B.I.G., G.N.G. or T.I.G. series. (See figure 1 for filter nomenclature)

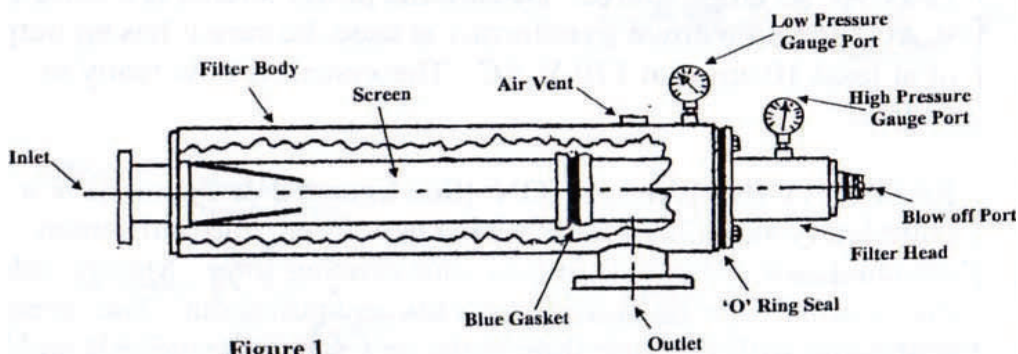
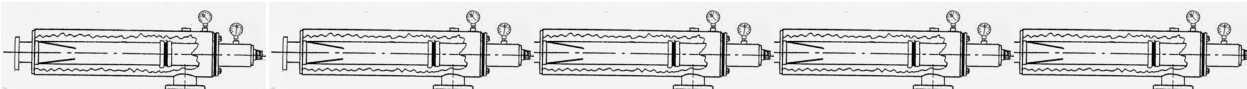

Figure 1

Installation

Your R.A.B. comes completely factory assembled. It is joined to a new filter head and screen.

NEW INSTALLATION: If your R.A.B. was purchased with a new filter then it is factory assembled to the filter body. Install the filter to you inlet and outlet pipes. Connect the electrical plug to a 120V AC, 5 amps source. Be sure the power source is a solid 120 V AC. If a step down transformer is used, be sure it has an output of at least 10 amps



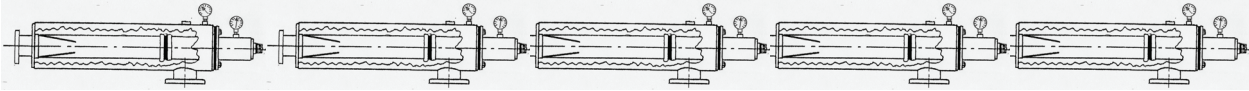

at 120V AC. The system is now ready to operate.

RETROFIT INSTALLATION: (See figures 2 & 3) you have a completely assembled RAB with a new filter head and screen attached to it. This will fit into your existing filter. Merely unbolt the existing filter head from the body and pull it out. The screen will come with it. Now slide in the new screen/head/RAB and bolt it on. CAUTION: DO NOT over tighten the nuts. You can break off the threaded studs. Draw up the head flange face until it contacts the 'O' ring gasket then tighten the nuts about 1/2 turn more. After the filter is pressurized, you may need to tighten one or two nuts about 1/4 turn if there is leaking. Again DO NOT over tighten the nuts.

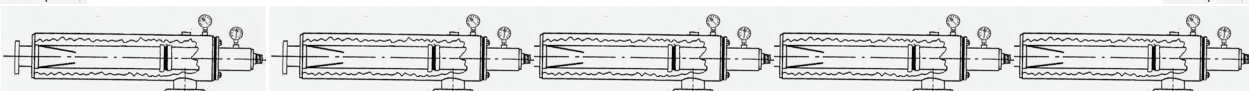
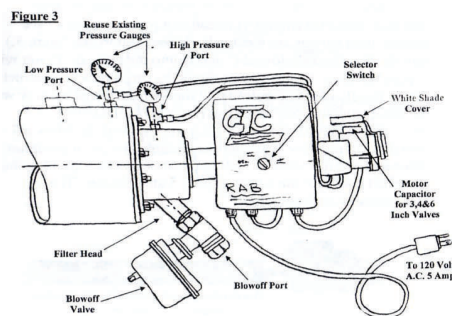
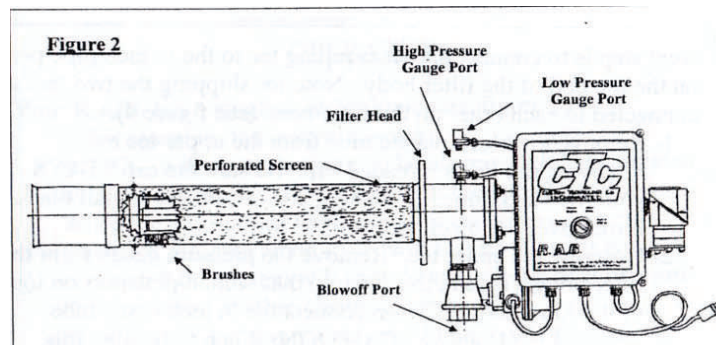
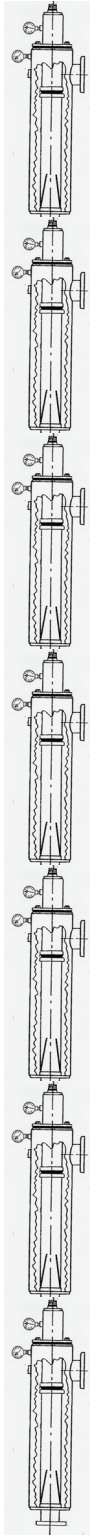
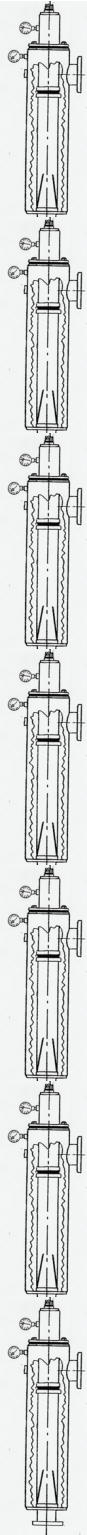

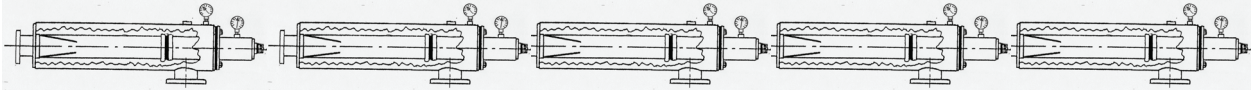

Next step is to connect the brass piping tee to the 1/4 inch pipe port on the top end of the filter body. Note for shipping the two tees are connected to each other on the filter head (see figure 4).

1-Remove the black plastic tube from the upper tee by removing the brass threaded cap. Be sure the cap STAYS with the black tube. If the cap falls off the very small black ferrell over the black tube will be lost.

2-Unscrew the upper tee. Remove the pressure gauge from the filter body. Thread this tee into that 1/4 inch pipe port on top of the filter body. Then reconnect the 1/4 inch black tube removed in (1) above. CAUTION: When tightening this brass cap, make it finger tight plus 1/2 wrench turn more; no more.

Into each brass tee (figure 4) thread in a pressure gauge. We suggest both gauges are identical. (Blow off port see figure 3). Simply, this can be allowed to spray onto the ground. If you wish to pipe the blow off away, you should be careful not to obstruct the flow. The R.A.B.s operation will totally be effected by how well the automatic blow off valve can pass debris. DO NOT RESTRICT THE BLOW OFF. If you pipe away the blow off, use oversize piping, keep it as short as possible and use a minimum of elbows. DO NOT connect to a line that is pressurized. Plug the

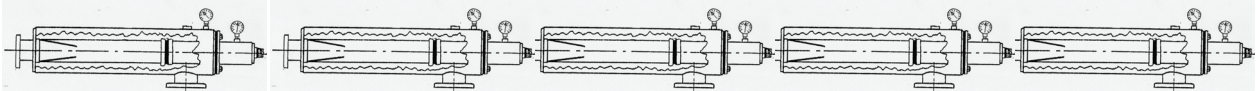

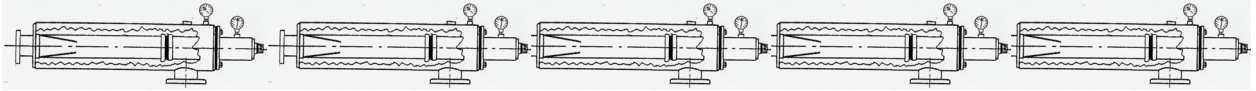

electric cord into the 120-volt AC 5 amp source. The installation is now complete.

Operation

Your R.A.B. has a single selector knob (see figure 3).

ON-energizes the control system

AUTO-will clean the filter. The cleaning cycle is initiated by the pressure switch on the side of the control enclosure. When the pressure difference across the screen element reaches 5 psi, a cleaning cycle will begin. When it is completed the system will shut down until the next pressure build up starts another cleaning cycle.

MANUAL-turning the selector knob to this position will start a cleaning cycle. As soon as you let go of the knob it moves to the AUTO position and stays there.

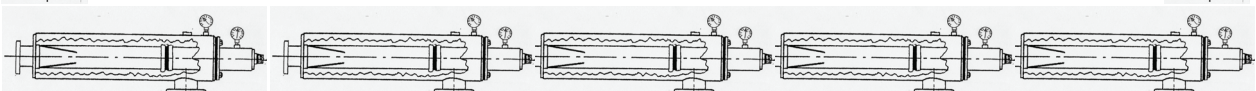
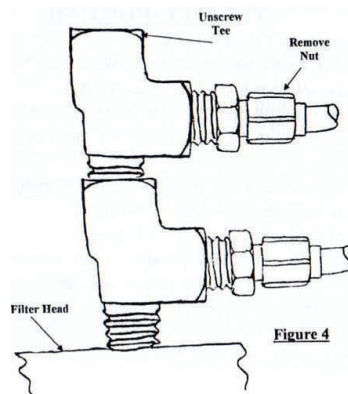
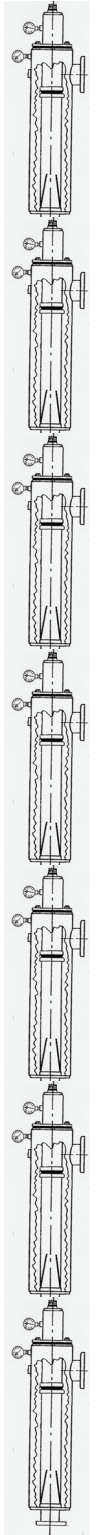
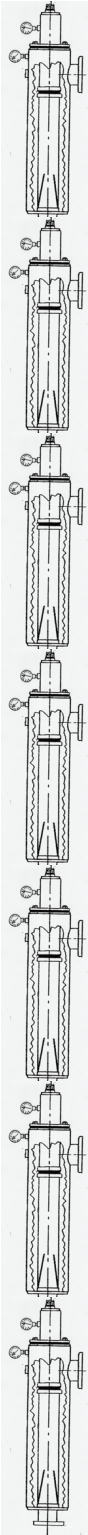

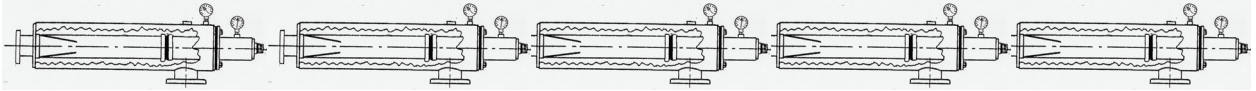

Accessory Counter

If your unit is fitted with a counter, it will be outside reading and reset on the control panel door. This is a useful tool to monitor R.A.B. operation.

Once above adjustments are complete, you will know in a few days what is a normal number of cleaning cycles per unit of time. If you suddenly observe a big difference in the number of cycles per measured time interval, then you may have a problem (see troubleshooting below).

Troubleshooting

1-System won't operate at all

- check fuse and incoming power
- turn selector switch to "MANUAL"

Valve should open (watch shaft on operator box on top of valve; it should rotate 90 degrees) and motor should run.

2-Motor runs but valve won't operate

- check inside valve operator (cover removed) for 120V AC across terminals (black and red or black and blue terminals).
- check that the "close" cam switch lever is depressed.

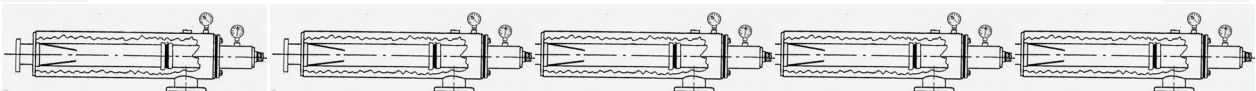

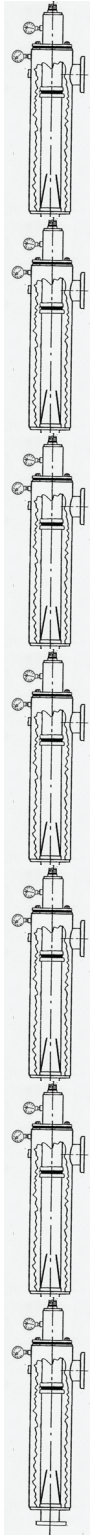
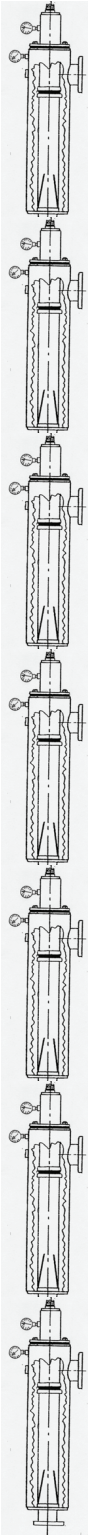
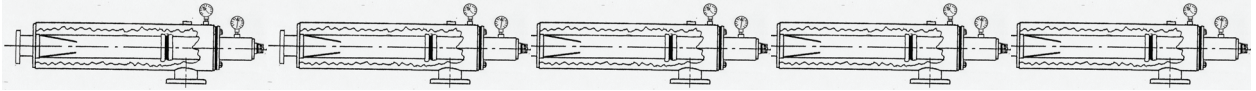

Position of cam switches may need adjusting.

3-Valve opens but brush motor won't run.

- check voltage on motor
- check capacitor on motor or inside control enclosure. The capacitor will be faulty if it is oozing black goo from holes in its housing.
- on the pressure differential switch system; this can happen if the differential is not going to zero at the end of the cleaning cycle. A new cycle will be initiated after completion of the previous cycle. The system is operating too frequently. This will cause the capacitor to overheat and fail. Hot weather will also bring this on. (For "frequent" see below).

4-Cycle seems OK but the cycles are getting gradually more frequent per day

- this could be a sign that the brush is wearing down and needs replacement.

5-Number of cycles per day has suddenly increased noticeably.

- disassemble head from filter body and check brush contact on the screen. Operate the R.A.B. in the manual mode and watch the brush's action from the open end of the screen. If it is worn too much, replace.

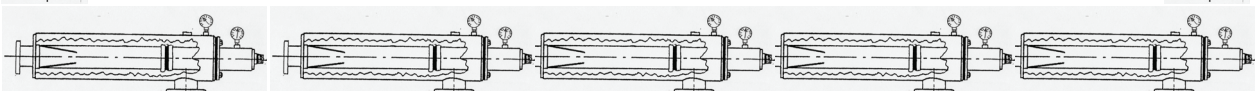

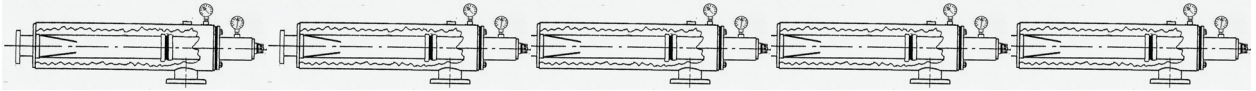

Maintenance

After 2 to 3 seasons the brushes will wear down and no longer be effective. Check the brushes by removing the filter head from the filter body. The entire RAB will stay with the head.

At the open end of the cylindrical screen (attached to the filter head) view the brushes. They should be slightly bent over and contacting the screen. If they are not touching the screen, then the brush weldment needs to be replaced.

Winterizing

When your filter and piping are drained or blown out for the winter, the RAB system must also be drained. Disconnect one of the black 1/4 plastic tubes. With a rod about 3/16 diameter, push upward on the bottom of the differential pressure switch (see figure 5).

Turn the selector switch to "MANUAL." watch that all water is drained from this valve. Then turn switch to "SYSTEM OFF." unplug the electric power cord.

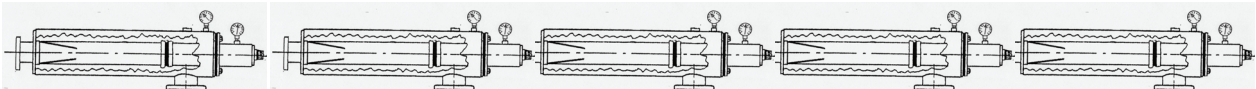

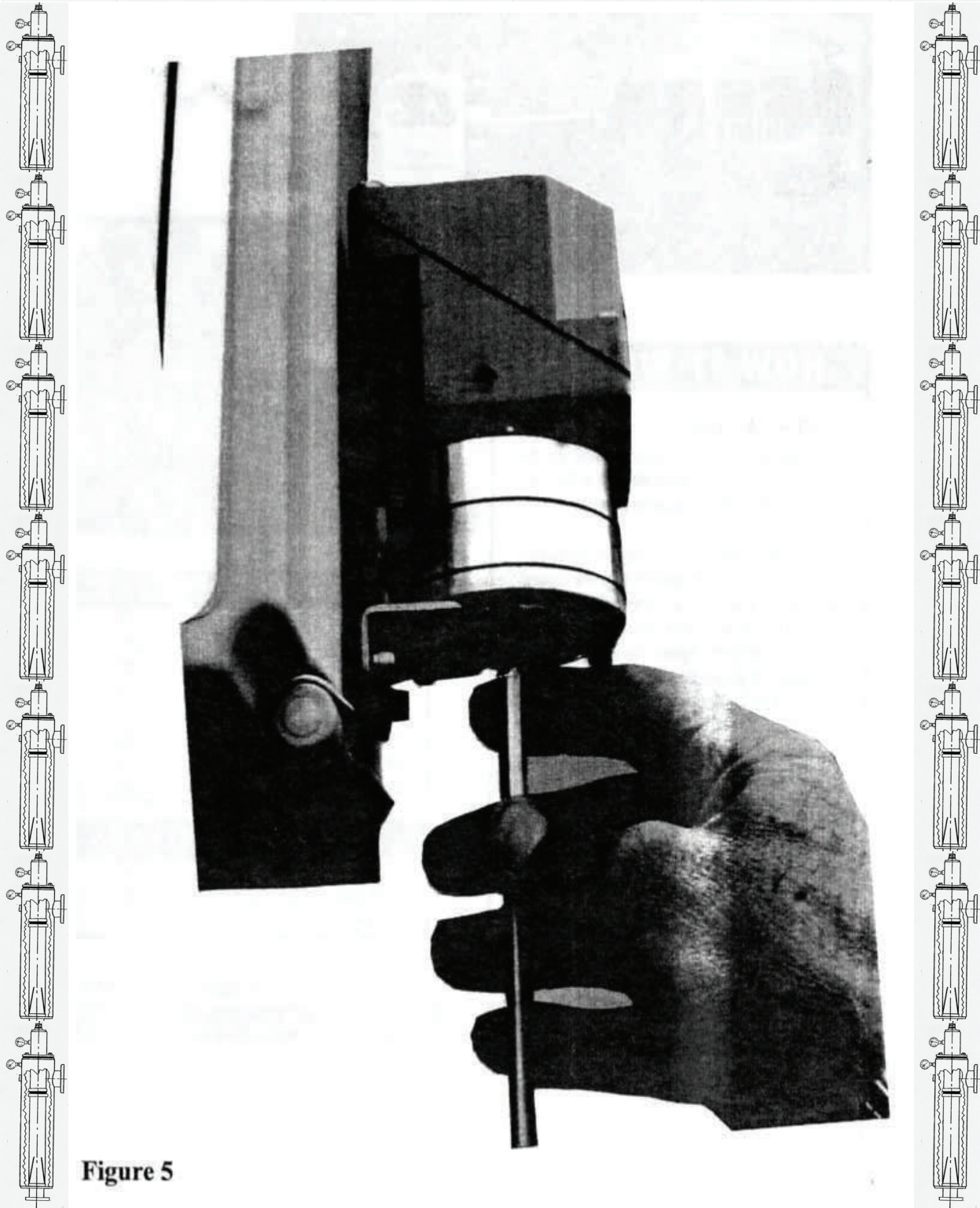
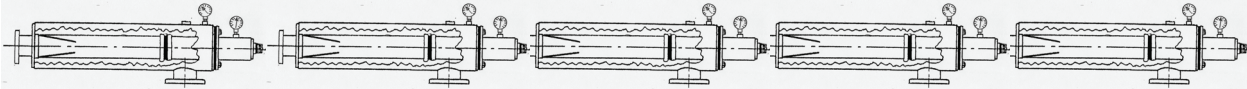
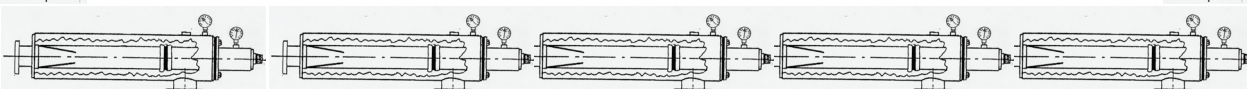
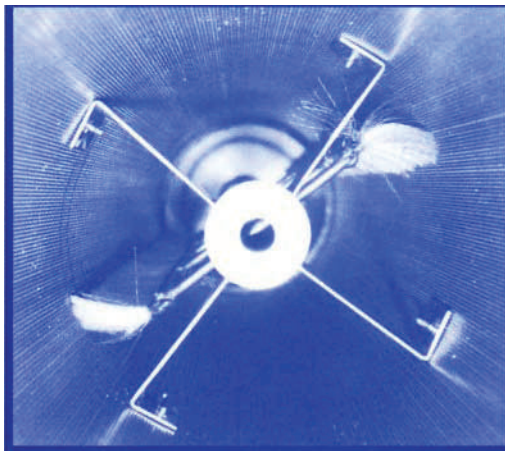
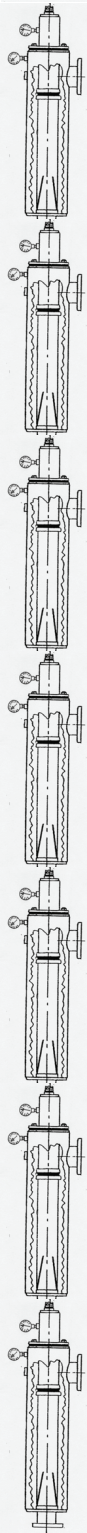
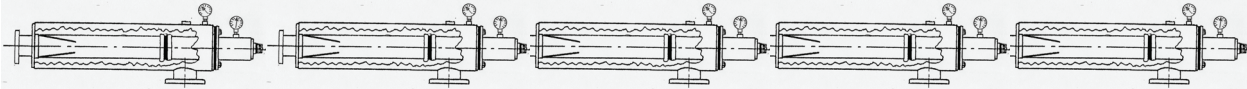

Figure 5





HOW IT WORKS

INSTALLATION:

For existing filters: the manual valve on the blow off port is removed and discarded. Then remove and discard the pressure gauges.

The RAB comes as one complete assembled unit. Insert the brush portion thru the blow off port into the filter. With the brush all the way into the filter the tee will come to the male pipe threads of the blow off port. Tighten the tee. Thread the two hose fittings into the existing pressure gauge ports (1/4 NPT). The last step is to plug the power cord into a 120V AC outlet. Your filter is now ready for automatic operation.

FOR BIG FILTERS

2"	BA509
3"	BA510
4"	BA511
6"	CA512
8"	CA513
10" small.....	DA514
10" medium.....	DA515
10" long.....	DA516

FOR GNG FILTERS

1000 gpm.....	BA517
1200 gpm.....	BA518
1500 gpm.....	BA519

OPERATION:

Set the controls for cleaning on a pressure differential basis. Blow off time is adjustable.

